

# BA Backflow Preventer STBA 600

Type BA - Filling unit for heating systems with pressure reducing valve



7

## Field of application

SYR's filling unit for heating systems STBA 600 with pressure reducing valve and integrated BA backflow preventer is a compact safety device in accordance with EN 1717, group B, with controllable disconnection (three zones system). It complies with the installation type BA as defined in EN 1717 and can be used as a protective device up to and including

fluid category 4. It is designed to prevent back-siphonage, backpressure or backflow of non-potable water into the public drinking water system. The filling unit for heating systems is mainly used as protective device when filling heating installations.

## Design

The filling unit for heating systems from SYR, which includes all components set by EN 1717 is designed as three zones system with a controllable upstream, intermediate and downstream pressure zone. It also includes a strainer. The pressure reducing valve can be set within a range from 1.5 to 6 bar. Each pressure zone can be equipped with test valves (accessories 6625.15.902) to verify the safety devices by pressure measurement. The backflow

preventer is equipped with two consecutive check valves with an intermediate pressure zone in between, which can be vented to the atmosphere. When no water is drawn off, the check valves on either side and the drain valve are closed. In case of back-siphonage, the inlet pressure drops. The drain valve opens at the latest, when the differential pressure between the upstream and intermediate zone decreases to 0.14 bar.

### Materials

The body is made of a high-quality low-lead brass alloy and heat-resistant synthetic material. The internal parts are made of high-quality corrosion resistant synthetic materials or stainless steel. All

synthetic parts getting in contact with drinking water are approved by the German Public Health Office (KTW). The valve's tundish is made of high-quality synthetic material.

### Installation

Permanent access to the valve has to be provided. Do not mount in rooms subject to flooding, frost or high temperatures. Install only in a well-ventilated environment. The connected discharge device must be able to collect the discharged volume. Mount the BA backflow preventer in vertical position with the

tundish connection facing downwards. Free access to the pressure test devices shall be provided to facilitate the inspection of the backflow preventer. It is recommended to install a drinking water filter upstream to ensure perfect function.

Thoroughly flush the pipe prior to installation. Mount the backflow preventer type BA in vertical

position under consideration of the direction of flow and without applying stresses.

### Technical specifications

Service pressure:	max. 10 bar
Service temperature:	max. 30°C (inlet), max 65°C (outlet)
Ambient temperature:	5°C - 40°C
Outlet pressure:	1.5 - 6 bar
Mounting position:	vertical, with tundish facing downwards
Fluid:	potable water
Flow rate:	1.27 m <sup>3</sup> /h at 1.5 bar -p
Serial number:	6625.15.006

### Maintenance

According to EN 806, part 5, the BA backflow preventer has to be serviced on a regular basis. Therefore maintenance agreements between user and installer are very useful. The correct function has to be verified after the first service year and then periodically in accordance with the operating conditions, but at the latest after one year. The

ball valves in each pressure zone allow to check the correct operation of the valve by means of corresponding measuring devices. The backflow preventer is designed with a cartridge system, which makes maintenance works simple and unproblematic.

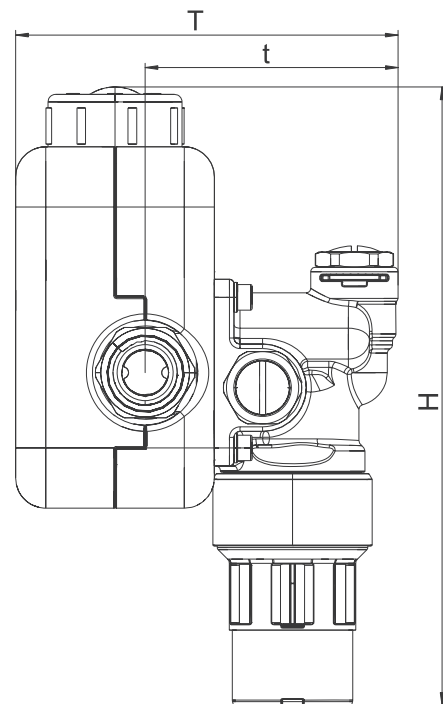
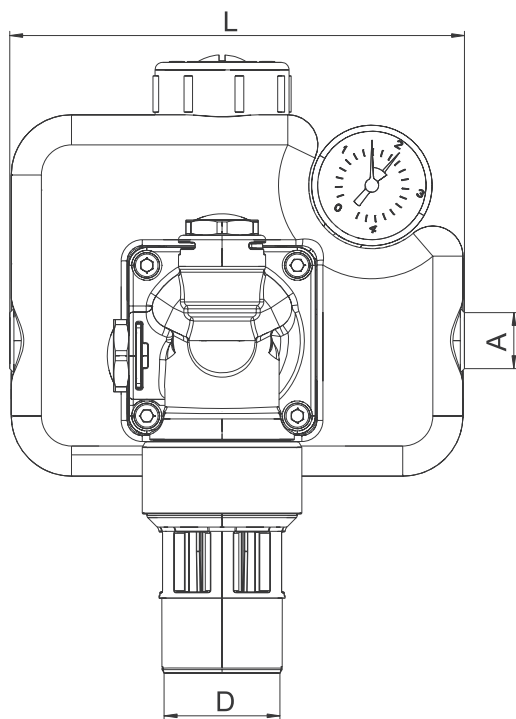

7

Nominal size		DN 15
Dimensions	A	R 1/2"
	L (mm)	151
	H (mm)	206
	T (mm)	127
	t (mm)	84
	D (mm)	40

**Accessories**

Service kit: Differential pressure measurement device for inspection and maintenance  
6600.00.000



# BA Backflow Preventer STBA 600

Components / Order numbers

- ① **Heat insulation cover**
- ② **Pressure reducer cartridge**  
6625.15.901
- ③ **Pressure gauge**
- ④ **Body**
- ⑤ **Backflow preventer cartridge**  
6625.15.900
- ⑥ **Four hexagon socket screws**
- ⑦ **Three test valves for inspection**  
6625.15.902

